

# TDSP

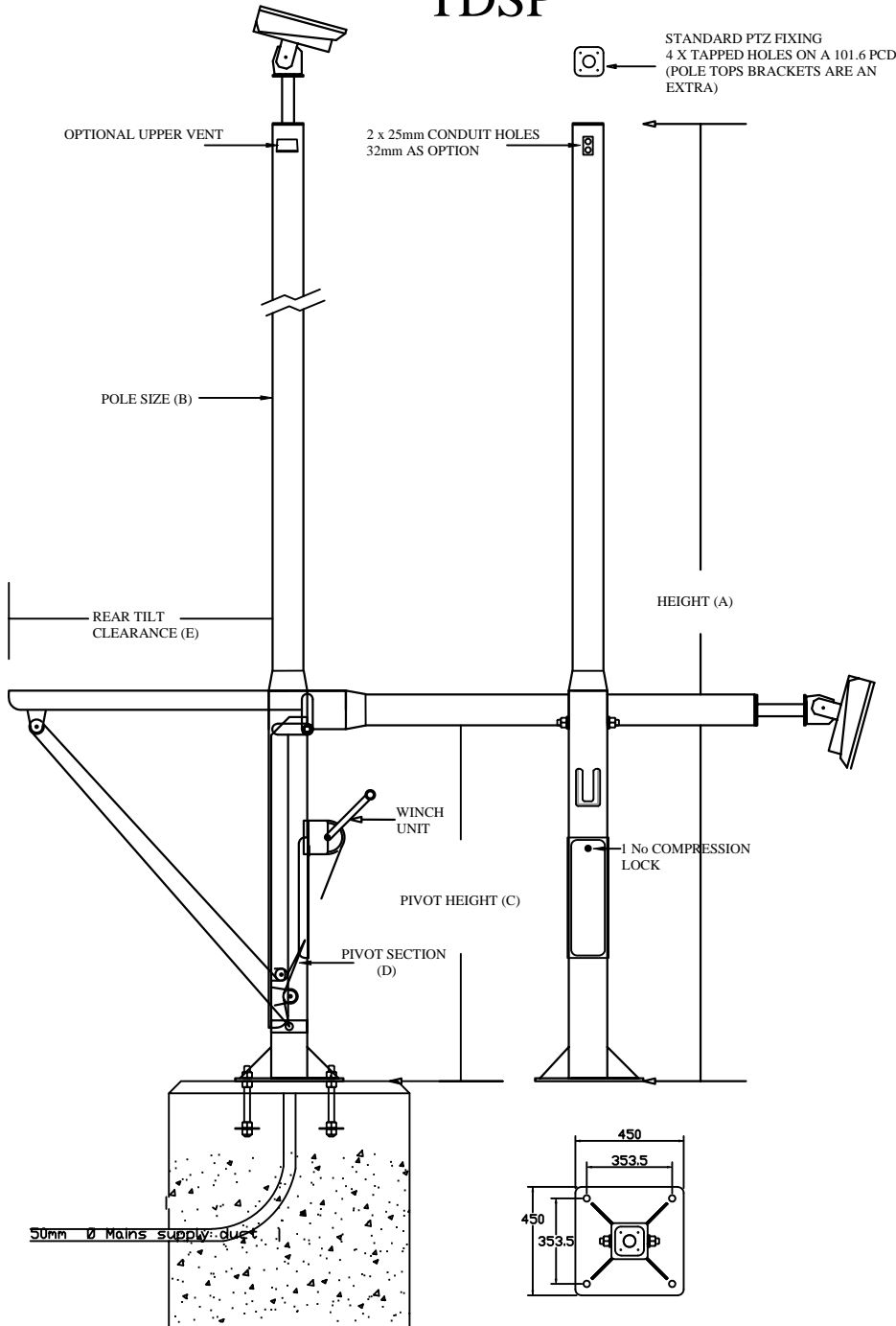

**MANUFACTURING STANDARDS:**

Structural Steelwork:  
BS EN 10210-1:1994, BS EN 10210-2:1997

General Steelwork:  
BS 4449:1991, BS 1387:1985, BS EN 10025:1993

Welding Procedures:  
Comply with BS 5135:1984

Hot Dipped Galvanized:  
BS EN 729:1971, BS EN ISO 1461:1999

Fasteners:  
Grade 8.8 BS3692:2001, BS 4190:2001,  
DIN 931, DIN 934

Design Wind Loadings:  
Based on CP3 Chapter V Pt 2 (1972) &  
BS 6399 Pt 2 (1997)

Paint Finishes:  
BS 4800 & RAL colour range

PRODUCT CODE	HEIGHT MTR A	POLE SIZE B	PIVOT HEIGHT C	PIVOT SECTION D	GUSSET THICKNESS	BASE PLATE THICKNESS	DOOR APERTURE DIMENSIONS	REAR TILT CLEARANCE E	WEIGHT KGS
TDSP4	4	120sq	1500	150sq	6	12	400 (h) x 180 (w)	1500	150
TDSP5	5	120sq	1500	150sq	6	12	400 (h) x 180 (w)	1500	162
TDSP6	6	120sq	1500	150sq	6	12	400 (h) x 180 (w)	1500	179
TDSP7	7	150sq	2000	200sq	8	15	450 (h) x 180 (w)	2000	198
TDSP8	8	150sq	2000	200sq	8	15	450 (h) x 180 (w)	2000	245
TDSP9	9	150sq	2500	200sq	10	20	450 (h) x 180 (w)	2500	329
TDSP10	10	150sq	2500	200sq	10	20	450 (h) x 180 (w)	2500	429
TDSP11	11	150sq	2500	200sq	12	25	451 (h) x 180 (w)	2500	479
TDSP12	12	150sq	2500	200sq	12	25	452 (h) x 180 (w)	2500	529

All dimensions in the above table are in mm unless otherwise stated.

DIAGRAM 1:  
Template assembled

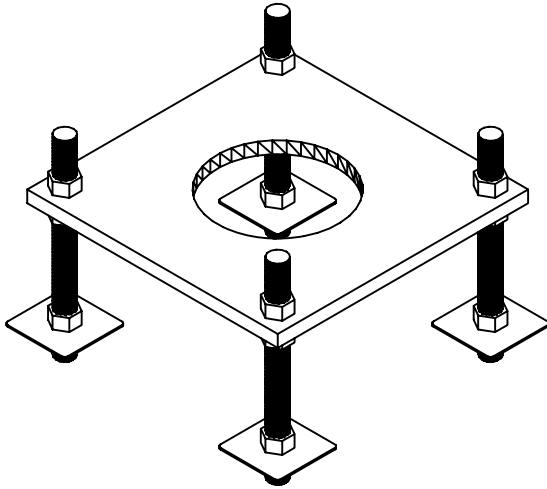
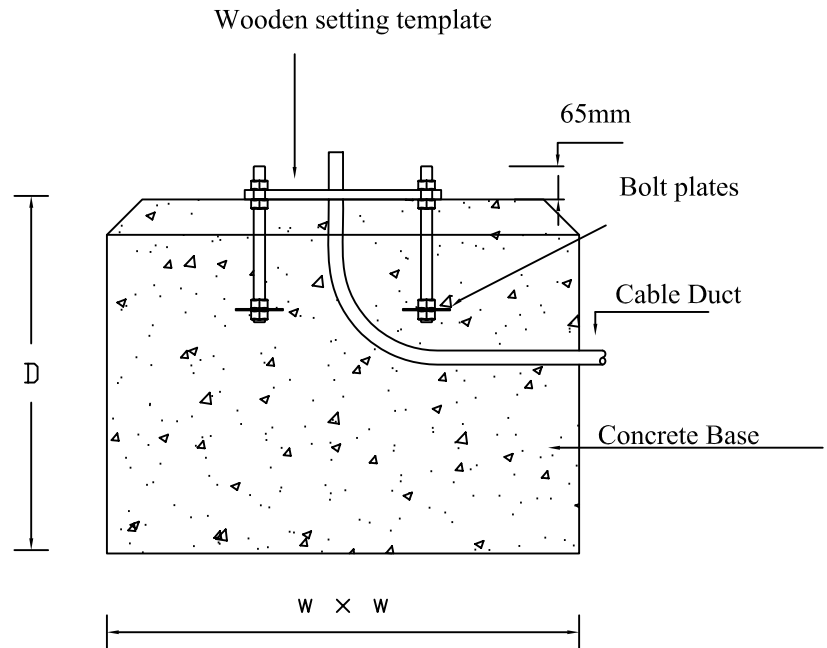

DIAGRAM 2:  
Foundation cross section



### PRODUCT CODE: TDSP FOUNDATION DETAILS

The below recommended foundation details are typical and some site conditions may require increased concrete base sizes. A minimum soil bearing of 75 n/m sq is assumed. We recommend pressures below the minimum are assessed by a structural engineer.

Product Code	Height	Base Area (W x W)	Depth	Concrete Vol M <sup>3</sup>
TDSP3	3 mtr	1000 x 1000	500	0.5
TDSP4	4 mtr	1000 x 1000	500	0.5
TDSP5	5 mtr	1000 x 1000	800	0.8
TDSP6	6 mtr	1000 x 1000	1000	1
TDSP7	7 mtr	1200 x 1200	1000	1.44
TDSP8	8 mtr	1300 x 1300	1000	1.69
TDSP9	9 mtr	1400 x 1300	1000	1.96
TDSP10	10 mtr	1500 x 1500	1000	2.25
TDSP11	11 mtr	1600 x 1600	1200	2.56
TDSP12	12 mtr	1750 x 1750	1200	3.67

1. Excavate hole as per recommended area and depth.
2. Assemble root base as shown in diagram 1 ensuring that it is level and that four studs protrude at 65mm above base of wooden setting template.
3. Ensure ducting is in place we recommend that a minimum of 150mm extrudes from ground level, if required this can be trimmed back once concrete is set.
4. Pour concrete ensuring that it is a mix of C35 to table 6 BS8110 and then tamp down well.
5. Push wooden template and bolts into concrete and level accordingly.
6. When fitting the column, remove wooden template and ensure that the concrete base is in complete contact with the underside of column and torque the nuts to 230-270 Nm (175 – 200 ft.lb)
7. When the column has been fitted, protect the studs with a suitable protective coating. Denzo tape or similar is recommended.
8. After re-instatement it is essential that a load bearing grout is used to fill the void between base plate and concrete, failure to do so may cause deflection in pole. It is recommended that the poles are grouted internally to ensure water tight.