

# FTP

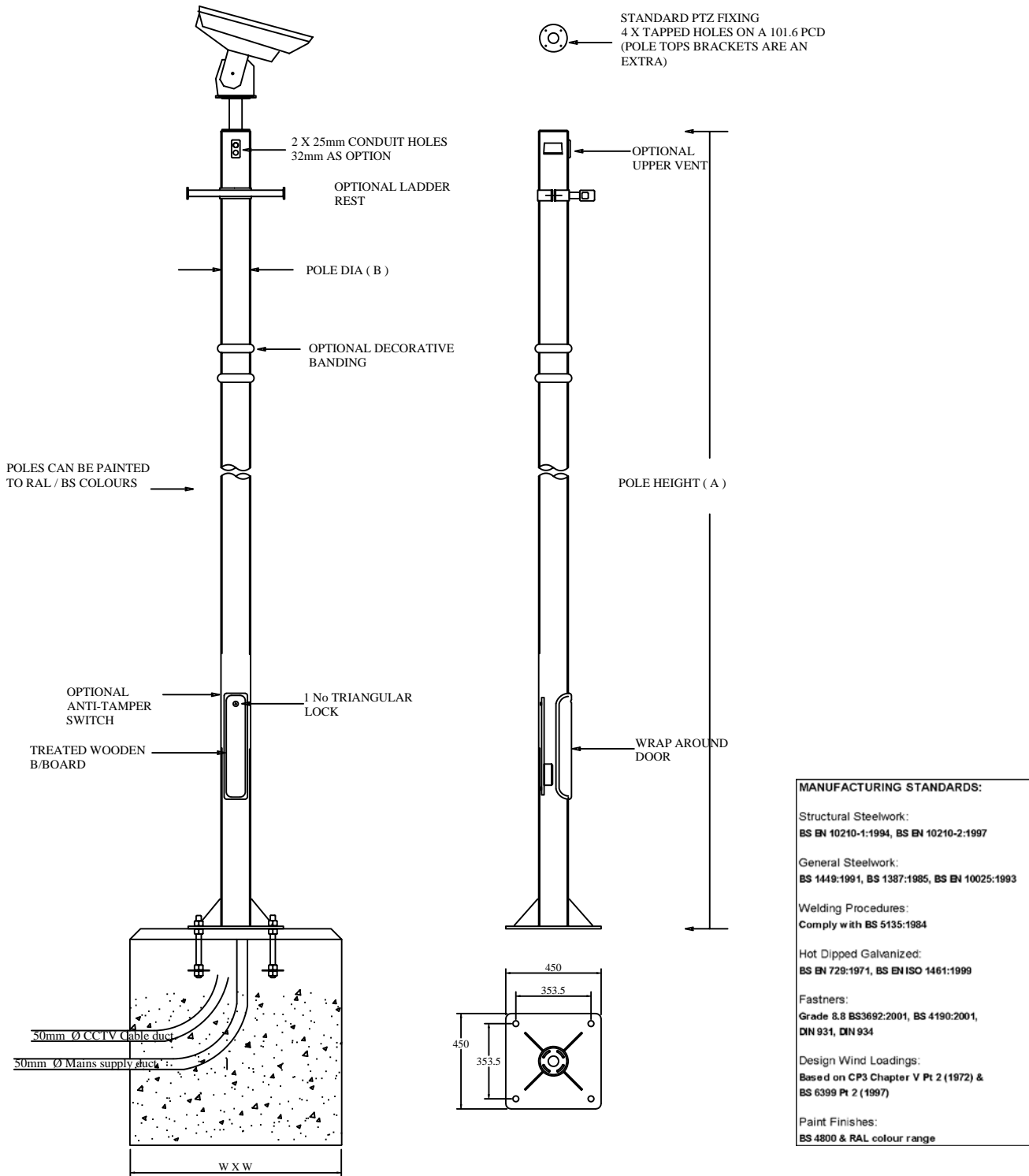

PRODUCT CODE	HEIGHT MTR A	POLE DIA B	GUSSET THICKNESS	BASEPLATE THICKNESS	DOOR APERTURE DIMENSION	WEIGHT KGS
FTP3	3	139	6	12	400 (h) X 90 (W)	100
FTP4	4	139	6	12	400 (h) X 90 (W)	110
FTP5	5	139	6	12	400 (h) X 90 (W)	130
FTP6	6	139	6	12	400 (h) X 90 (W)	150
FTP7	7	168	8	15	450 (h) X 120 (W)	225
FTP8	8	168	8	15	450 (h) X 120 (W)	248
FTP9	9	219	10	20	500 (h) X 175 (W)	359
FTP10	10	219	10	20	500 (h) X 175 (W)	400
FTP11	11	219	15	25	500 (h) X 175 (W)	425
FTP12	12	219	15	25	500 (h) X 175 (W)	460

All dimensions in the above table are in mm unless otherwise stated.

DIAGRAM 1:

Template assembled

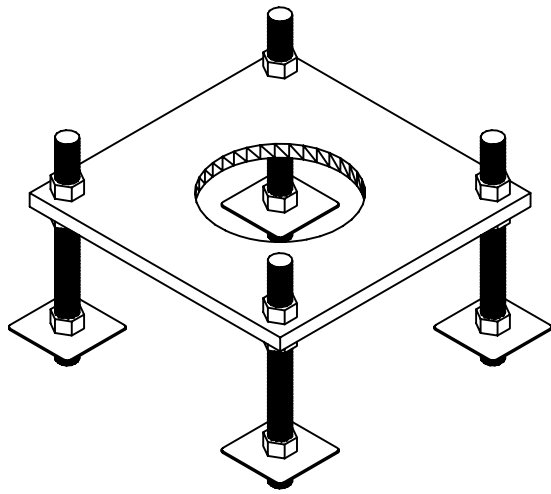
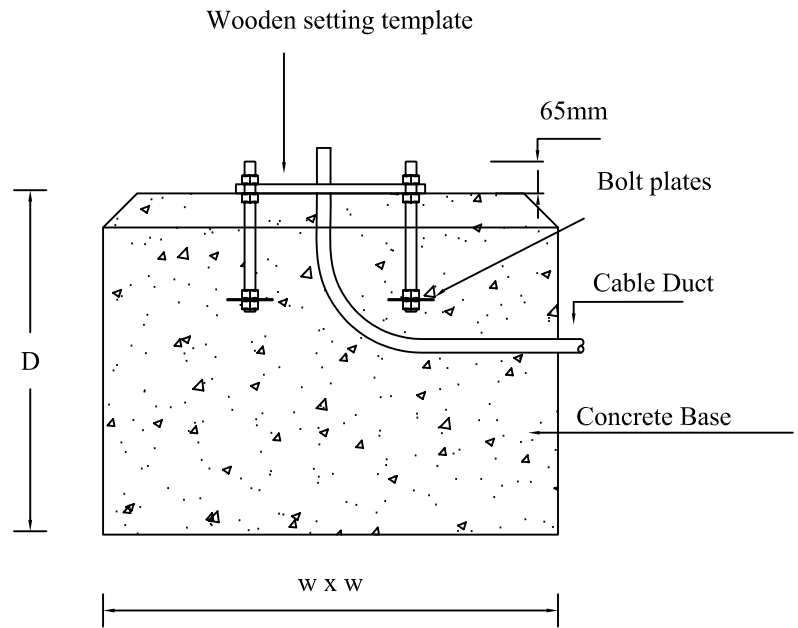

DIAGRAM 2:

Foundation cross section



## PRODUCT CODE: FTP FOUNDATION DETAILS

The below recommended foundation details are typical and some site conditions may require increased concrete base sizes. A minimum soil bearing of 75 n/m sq is assumed. We recommend pressures below the minimum are assessed by a structural engineer.

Product Code	Height	Base Area (W x W)	Depth	Concrete Vol M <sup>3</sup>
FTP3	3 mtr	800 x 800	500	0.32
FTP4	4 mtr	1000 x 1000	500	0.5
FTP5	5 mtr	1000 x 1000	750	0.75
FTP6	6 mtr	1000 x 1000	1000	1
FTP7	7 mtr	1200 x 1200	1000	1.44
FTP8	8 mtr	1300 x 1300	1000	1.69
FTP9	9 mtr	1400 x 1300	1000	1.96
FTP10	10 mtr	1500 x 1500	1000	2.25
FTP11	11 mtr	1700 x 1700	1200	3.46
FTP12	12 mtr	1750 x 1750	1200	3.67

1. Excavate hole as per recommended area and depth.
2. Assemble root base as shown in diagram 1 ensuring that it is level and that four studs protrude at 65mm above base of wooden setting template.
3. Ensure ducting is in place we recommend that a minimum of 150mm extrudes from ground level, if required this can be trimmed back once concrete is set.
4. Pour concrete ensuring that it is a mix of C35 to table 6 BS8110 and then tamp down well.
5. Push wooden template and bolts into concrete and level accordingly.
6. When fitting the column, remove wooden template and ensure that the concrete base is in complete contact with the underside of column and torque the nuts to 230-270 Nm (175 – 200 ft.lb)
7. When the column has been fitted, protect the studs with a suitable protective coating. Denzo tape or similar is recommended.
8. After re-instatement it is essential that a load bearing grout is used to fill the void between base plate and concrete, failure to do so may cause deflection in pole. It is recommended that the poles are grouted internally to ensure water tight.