

ACME FHP-CHELSEA

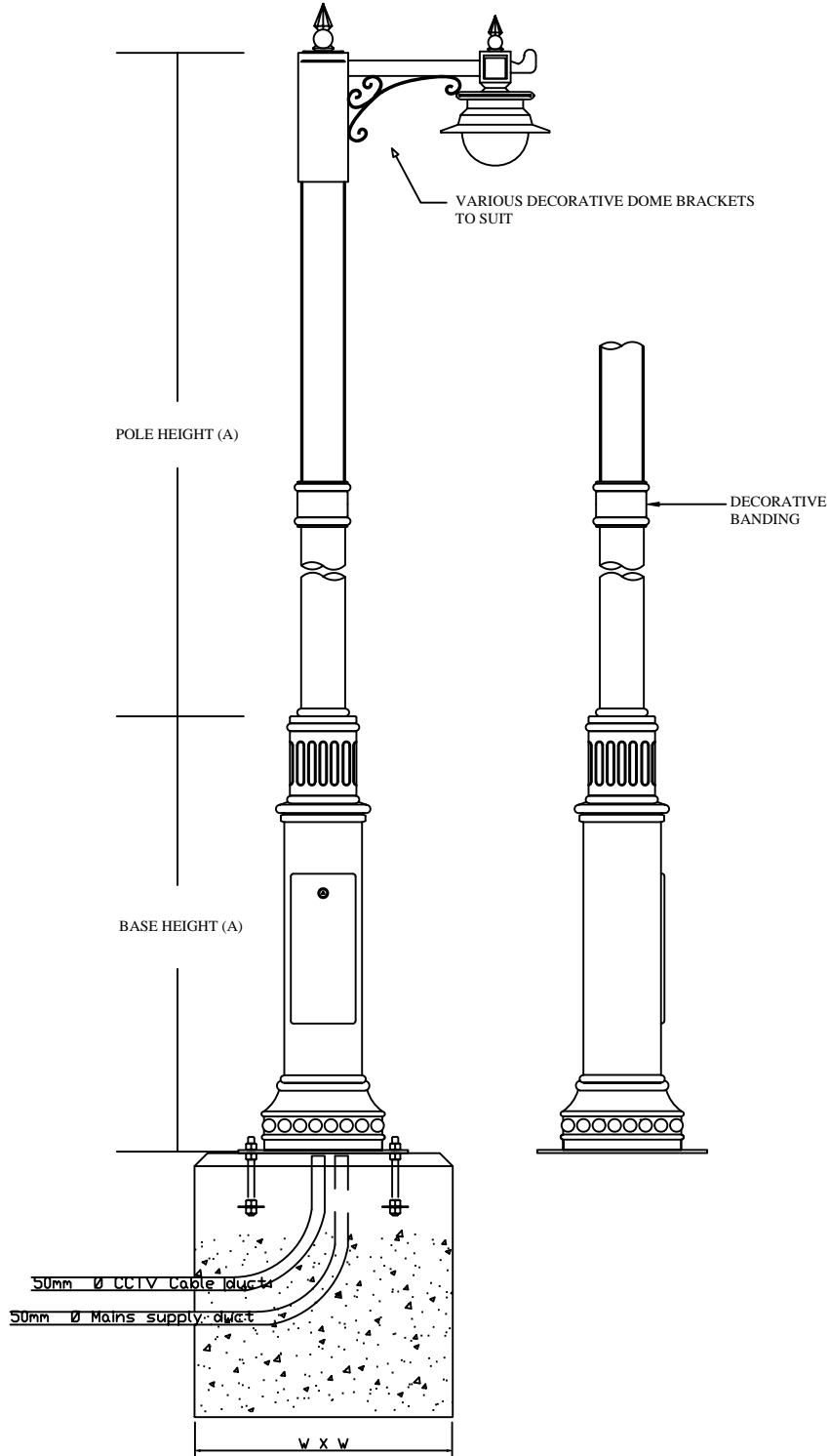

MANUFACTURING STANDARDS:

Structural Steelwork:
BS EN 10210-1:1994, BS EN 10210-2:1997

General Steelwork:
BS 1449:1991, BS 1387:1985, BS EN 10025:1993

Welding Procedures:
Comply with BS 5135:1984

Hot Dipped Galvanized:
BS EN 729:1971, BS EN ISO 1461:1999

Fasteners:
Grade 8.8 BS 3692:2001, BS 4190:2001,
DIN 931, DIN 934

Design Wind Loadings:
Based on CP3 Chapter V Pt 2 (1972) &
BS 6399 Pt 2 (1997)

Paint Finishes:
BS 4800 & RAL colour range

PRODUCT CODE	HEIGHT MTR A	POLE DIA B	BASE DIA C	BASE HEIGHT D	GUSSET THICKNESS	BASE PLATE THICKNESS	DOOR APERTURE DIMENSION	WEIGHT KGS
FHPC3	3	139	193	1500	6	12	400 (h) X 90 (W)	85
FHPC4	4	139	193	1500	6	12	400 (h) X 90 (W)	123
FHPC5	5	139	193	1500	6	12	400 (h) X 90 (W)	219
FHPC6	6	139	193	1500	6	12	400 (h) X 90 (W)	242
FHPC7	7	168	273	2000	8	15	450 (h) X 120 (W)	269
FHPC8	8	168	273	2000	8	15	450 (h) X 120 (W)	348
FHPC9	9	168	273	2500	10	20	500 (h) X 175 (W)	571
FHPC10	10	168	273	2500	10	20	500 (h) X 175 (W)	616
FHPC11	11	168	323	2500	15	25	500 (h) X 175 (W)	661
FHPC12	12	168	323	2500	15	25	500 (h) X 175 (W)	706

All dimensions in the above table are in mm unless otherwise stated.

DIAGRAM 1:
Template assembled

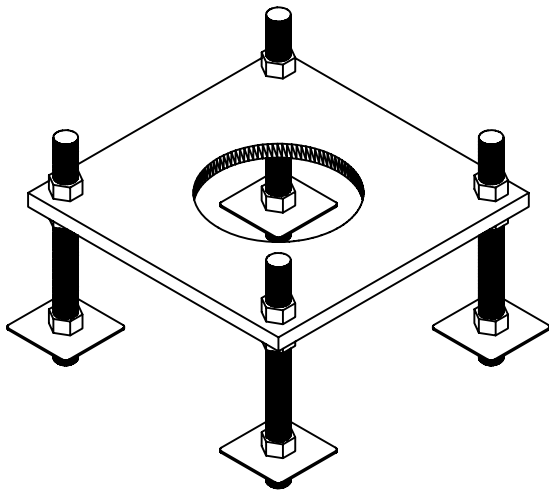
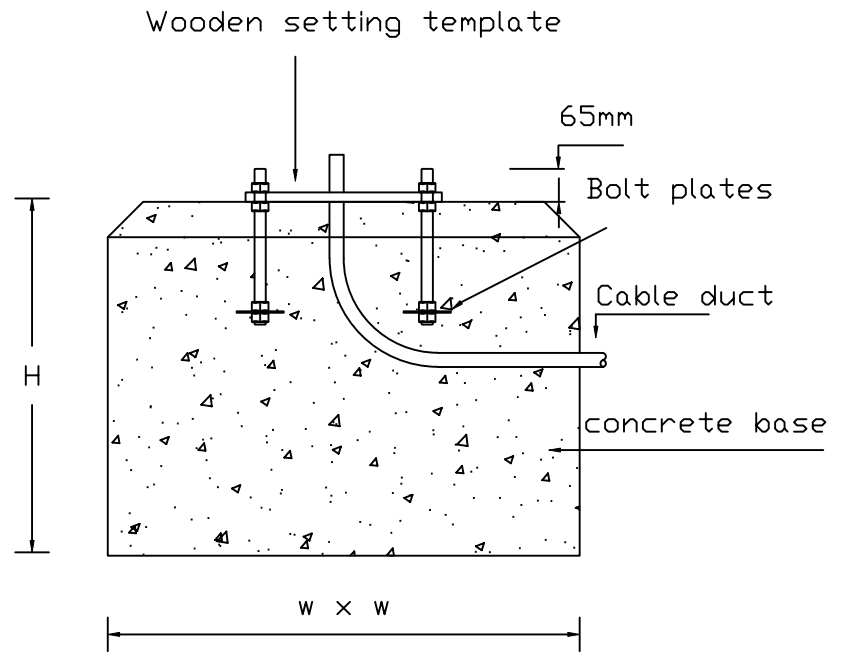

DIAGRAM 2:
Foundation cross section



PRODUCT CODE: FHP FOUNDATION DETAILS

The below recommended foundation details are typical and some site conditions may require increased concrete base sizes. A minimum soil bearing of 75 n/m sq is assumed. We recommend pressures below the minimum are assessed by a structural engineer.

Product Code	Height	Base Area (W x W)	Depth	Concrete Vol M ³
FMV3	3 mtr	800 x 800	500	0.32
FMV4	4 mtr	1000 x 1000	500	0.5
FMV5	5 mtr	1000 x 1000	750	0.75
FMV6	6 mtr	1000 x 1000	1000	1
FMV7	7 mtr	1200 x 1200	1000	1.44
FMV8	8 mtr	1300 x 1300	1000	1.69
FMV9	9 mtr	1400 x 1300	1000	1.96
FMV10	10 mtr	1500 x 1500	1000	2.25
FMV11	11 mtr	1700 x 1700	1200	3.46
FMV12	12 mtr	1750 x 1750	1200	3.67

1. Excavate hole as per recommended area and depth.
2. Assemble root base as shown in diagram 1 ensuring that it is level and that four studs protrude at 65mm above base of wooden setting template.
3. Ensure ducting is in place we recommend that a minimum of 150mm extrudes from ground level, if required this can be trimmed back once concrete is set.
4. Pour concrete ensuring that it is a mix of C35 to table 6 BS8110 and then tamp down well.
5. Push wooden template and bolts into concrete and level accordingly.
6. When fitting the column, remove wooden template and ensure that the concrete base is in complete contact with the underside of column and torque the nuts to 230-270 Nm (175 – 200 ft.lb)
7. When the column has been fitted, protect the studs with a suitable protective coating. Denzo tape or similar is recommended.